

INtouch WITH TIMBER 2010

Achieving Thermal Comfort using Timber Frame

Robin Lancashire
Timber Frame Consultant
TRADA Technology



INtouch WITH TIMBER 2010

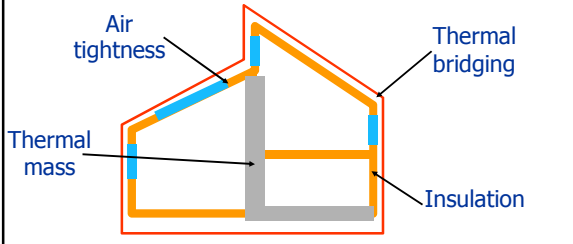

Air tightness

Thermal bridging

Thermal mass

Insulation



INtouch WITH TIMBER 2010

INSULATION

London County Council TRADA SEMLAC Frameform

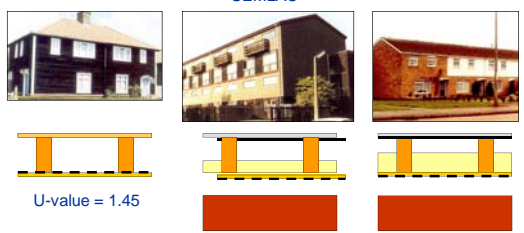

U-value = 1.45 U-value = 0.85 U-value = 0.60



INtouch WITH TIMBER 2010

Stud = 140mm 190mm 240mm

Inside

- Dry lining
- Vapour control
- Stud + insulation
- Sheathing
- Breather membrane
- Cavity
- Cladding

Outside

U-value = 0.30 0.24 0.18





INtouch WITH TIMBER 2010

Make walls thicker - but...

- Reduced floor area
- More materials used
- Manual handling during build

So...

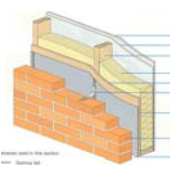

- Add reflective membranes
- Use a more efficient insulation

INtouch WITH TIMBER 2010

TRADA Technology Timber frame. Standard Details for Houses and Flats. H-EX-22

H-EX-22 Junction of external wall and cold roof with breathable roof membrane; at eaves - Scale 1:10

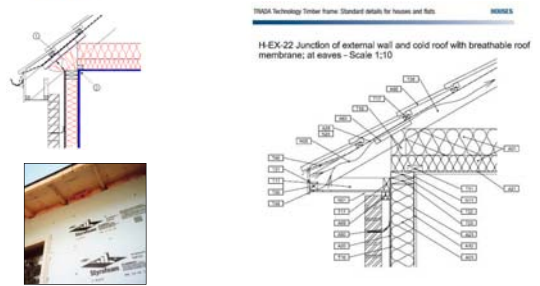
INtouch WITH TIMBER 2010

- Assume 15% timber fraction in external walls. Reduced insulation area and more thermal bridging can occur



TRADA

INtouch WITH TIMBER 2010 THERMAL BRIDGING

- gaps within the various elements.
- at the joints between elements
- at the edges of elements such as those around windows

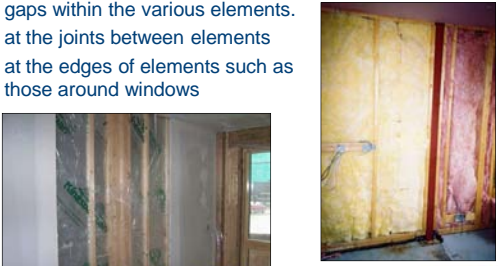

TRADA

INtouch WITH TIMBER 2010

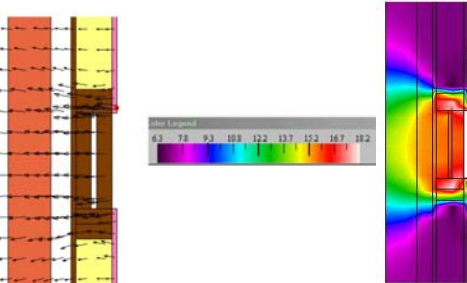

TRADA

INtouch WITH TIMBER 2010

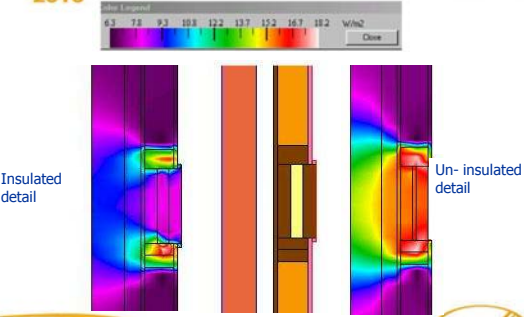

Insulated detail

Un-insulated detail

TRADA

INtouch WITH TIMBER 2010

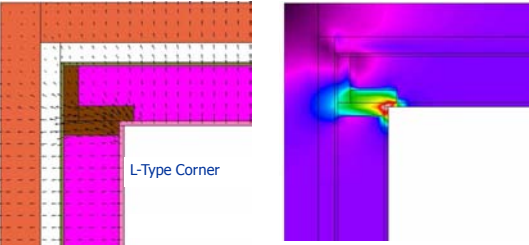

L-Type Corner

TRADA

INtouch WITH TIMBER 2010

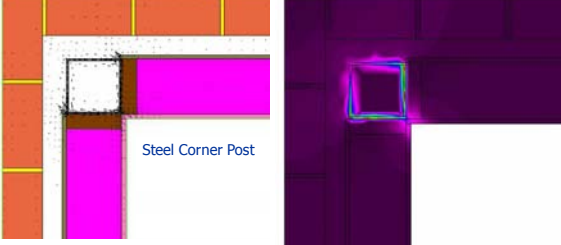

Steel Corner Post

TRADA

INtouch WITH TIMBER 2010



THERMAL BRIDGING- The effects

- In practice, timber fractions can be much higher than 15%
- Thermal bridging bypasses thermal insulation, leading to increased heat flow through the thermal envelope.
- Increased space heating requirements.
- In winter, low internal surface temperatures around the thermal bridge.
- Risk of local surface condensation.



INtouch WITH TIMBER 2010



THERMAL BRIDGING- Minimising

- 15% timber fraction - 'over engineering' can lead to higher timber fractions
- Effective placement of insulation
- I-beams - reduced cross sectional area
- Double stud wall - 'breaks' thermal bridge
- Warm wall - maintains continuity of insulation
- Insulated drylining - maintains continuity of insulation



INtouch WITH TIMBER 2010



THERMAL BRIDGING - Advanced framing

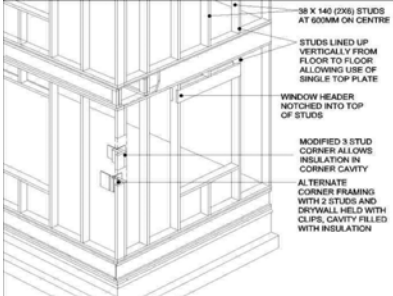

90 X 140 (200) STUDS AT 600MM ON CENTRE

STUDS LINED UP VERTICALLY FROM FLOOR TO FLOOR ALLOWING USE OF SINGLE TOP PLATE

WINDOW HEADER NOTCHED INTO TOP OF STUDS

MODIFIED 3 STUD CORNER ALLOWS INSULATION IN CORNER CAVITY

ALTERNATE CORNER FRAMING WITH 2 STUDS AND DRYWALL HELD WITH CLIPS, CAVITY FILLED WITH INSULATION



INtouch WITH TIMBER 2010

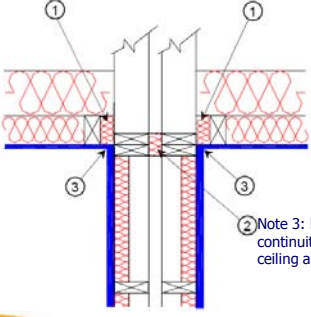



Note 3: Ensure air barrier continuity between the ceiling and the wall linings



INtouch WITH TIMBER 2010

Thermal mass



- Timber frame is efficient without thermal mass

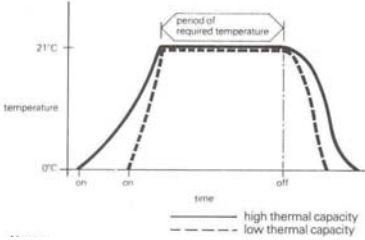

21°C

0°C

temperature

time

period of required temperature

— high thermal capacity

- - - low thermal capacity



INtouch WITH TIMBER 2010



Air tightness

Infiltration / Exfiltration

- Air moving through the thermal envelope into the dwelling has to be heated in order to maintain internal temperatures
- Any movement of this air to the outside will result in heat loss
- Air leakage from the inside of the building to the outside (exfiltration) will transport the water vapour it contains. This can be up to 30 times higher than vapour diffusion



INtouch WITH TIMBER 2010 - Why bother?

- 4 very good reasons
 - Protects the building envelope
 - Promotes energy efficiency
 - Better ventilation control
 - Reduces outdoor noise, odours and dust
- But remember: Airtightness is cumulative
 - Good workmanship in the construction of the entire building envelope is essential to its proper performance
 - Properly installed air barriers are not a cure-all for poor construction practices



INtouch WITH TIMBER 2010 Testing

- Average Swedish leakage rate is about 2.4 ac/h at 50Pa
- Canadian R2000 leakage rate is consistently below 1 ac/h at 50Pa
- Average UK leakage rates historically between 12-14 ac/h at 50Pa
- UK building regulations now require testing



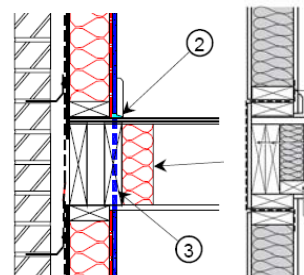

INtouch WITH TIMBER 2010



Breather membrane and vcl not shown for clarity. Upper external wall breather membrane would lap with lower wall breather membrane. Air barrier to lap with vcl



- Air barrier
- Floor deck
- Header joists
- Insulation when specified for acoustics performance
- Nogging to support ceiling lining

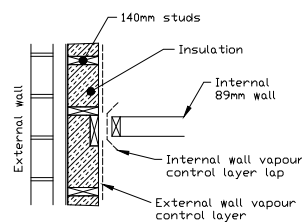

INtouch WITH TIMBER 2010



- 140mm studs
- Insulation
- Internal 89mm wall
- Internal wall vapour control layer lap
- External wall vapour control layer

INtouch WITH TIMBER 2010



Air Tightness Detailing Around Services



INtouch WITH TIMBER 2010

Air leakage vs. Ventilation

- Airtightness cannot be considered in isolation from ventilation
- Ventilation is essential for a healthy indoor environment

But;

- Ventilation is a source of heat loss, So;
- It is necessary to control the flow of air through the dwelling



INtouch
WITH TIMBER
2010



CONSTRUCTION QUALITY - The bad.....



TRADA

INtouch
WITH TIMBER
2010



CONSTRUCTION QUALITY - and the good



TRADA

INtouch
WITH TIMBER
2010



**Achieving Thermal Comfort
using Timber Frame**

Robin Lancashire
Timber Frame Consultant
TRADA Technology

TRADA